

# MINIATURE FLOAT PIVOTED SWITCHES-**MFPS** SERIES

*They are compact, economical and reliable level switches used for level detection in small tank /machine/equipment, where limited space is available inside /outside.*

## CONSTRUCTION & OPERATION

Each switch consists of a float with a trim carrying magnet and moving around a pivot on the switch enclosure. During rising & falling of liquid, float follows the liquid level and actuates the reed switch. It is side mounted to the tank wall. Reversible switch action - is achieved in few models by 180° switch rotation.

## SERVICES & APPLICATIONS

Water, hydrocarbons, edible oils, acids & alkalies, vending machines for food, beverage, tea & coffee, chiller compressor, plastic extruder, spark erosion/ special purpose/ hydraulic machines, humidifier, dosing equipment's for water effluent treatment plants and bilge level control in ships.



**Dosing Tanks in  
Water Treatment Plant**



**Plastic Extruder**

## INSTALLATION

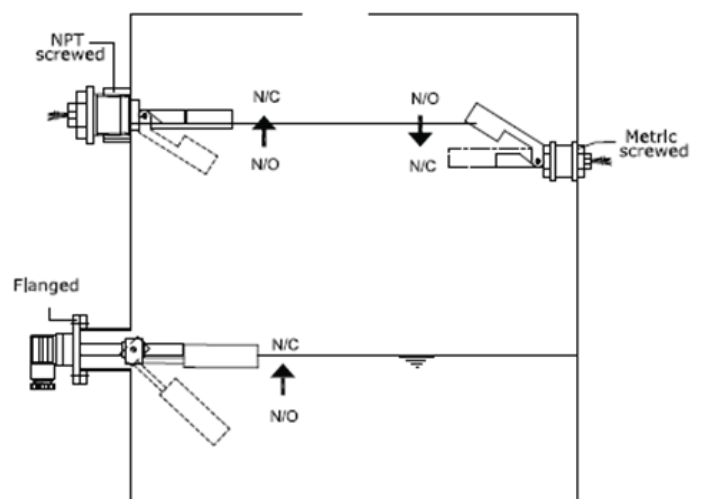

## MFPS - Q12E

Liquid Sp. Gr. Min	: 0.7
Temperature Max	: 70 °C
Test Pressure Max	: 1 Kg/cm <sup>2</sup>
MOC	: PP
Float	: Ø17
Extension	: Without
Connection	: M16 with washer & locknut
Switch Capacity	: 10 VA (NO type)
Switch Action	: NO to NC (float rising)
Reversible Switch Action	: Yes
Differential	: ±3 mm
Switching Voltage Max	: 140 VAC/200 VDC
Switching Current Max	: 0.5 A
Termination	: 300 mm extn. leads

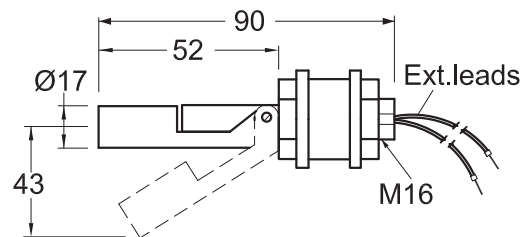

## MFPS - Q15E

Liquid Sp. Gr. Min	: 0.7
Temperature Max	: 70 °C
Test Pressure Max	: 1 Kg/cm <sup>2</sup>
MOC	: PP
Float	: Ø17
Extension	: Without
Connection	: 1/2"NPT (M)
Switch Capacity	: 10 VA (NO type)
Switch Action	: NO to NC (float rising)
Reversible Switch Action	: Yes
Differential	: ±3 mm
Switching Voltage Max	: 140 VAC/200 VDC
Switching Current Max	: 0.5 A
Termination	: 300 mm extn. leads

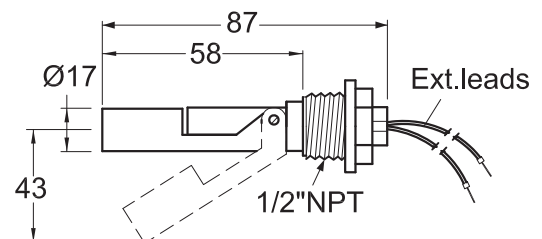

## MFFPS - Q13E Specially designed for coolant filtration tant

Liquid Sp. Gr. Min	: 0.7
Temperature Max	: 70 °C
Test Pressure Max	: 1 Kg/cm <sup>2</sup>
MOC	: PP
Float	: Ø27
Extension	: Without
Connection	: M16 with washer & locknut
Switch Capacity	: 10 VA (NO type)
Switch Action	: NC to NO (float rising)
Reversible Switch Action	: No
Differential	: ±3 mm
Switching Voltage Max	: 140 VAC/200 VDC
Switching Current Max	: 0.5 A
Termination	: 300 mm extn. leads



Specially designed float trim prevents deposition of iron particles/shavings around the pivot which inhibits switch operation.

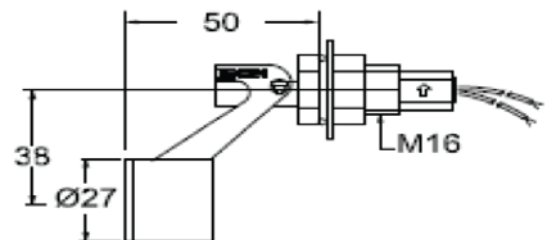

## MFPS - Q12C

Liquid Sp. Gr. Min	: 0.7
Temperature Max	: 70 °C
Test Pressure Max	: 1 Kg/cm <sup>2</sup>
MOC	: PP
Float	: Ø17
Extension	: 150 mm
Connection	: 1"NB ASME 150# Flange
Switch Capacity	: 10 VA (NO type)
Switch Action	: NO to NC (float rising)
Reversible Switch Action	: No
Differential	: ±3 mm
Switching Voltage Max	: 140 VAC/200 VDC
Switching Current Max	: 0.5 A
Termination	: Plug In Connector

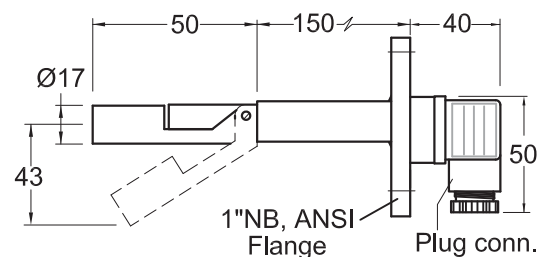

## MFPS - Q12J

Liquid Sp. Gr. Min	: 0.7
Temperature Max	: 70 °C
Test Pressure Max	: 1 Kg/cm <sup>2</sup>
MOC	: PP
Float	: Ø17
Extension	: 150 mm
Connection	: 1"NB ASME 150# Flange
Switch Capacity	: 10 VA (NO type)
Switch Action	: NO to NC (float rising)
Reversible Switch Action	: No
Differential	: ±3 mm
Switching Voltage Max	: 140 VAC/200 VDC
Switching Current Max	: 0.5 A
Termination	: Cast Al. Enclosure IP66

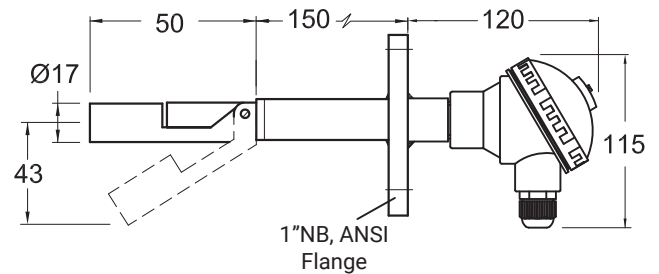

## MFPS - Q15C

Liquid Sp. Gr. Min	: 0.7
Temperature Max	: 70 °C
Test Pressure Max	: 1 Kg/cm <sup>2</sup>
MOC	: PP
Float	: Ø17
Extension	: Without
Connection	: ½"NPT (M)
Switch Capacity	: 10 VA (NO type)
Switch Action	: NO to NC (float rising)
Reversible Switch Action	: No
Differential	: ±3 mm
Switching Voltage Max	: 140 VAC/200 VDC
Switching Current Max	: 0.5 A
Termination	: Plug In Connector

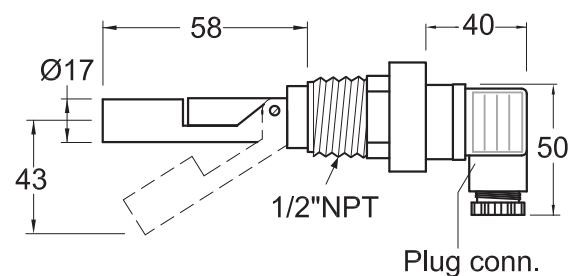

## MFPS - N11E

Liquid Sp. Gr. Min	: 0.8
Temperature Max	: 130 °C
Test Pressure Max	: 5 Kg/cm <sup>2</sup>
MOC	: SS304
Float	: Ø17
Extension	: Without
Connection	: M10 with washer & locknut
Switch Capacity	: 10 VA (NO type)
Switch Action	: NO to NC (float rising)
Reversible Switch Action	: Yes
Differential	: ±3 mm
Switching Voltage Max	: 140 VAC/200 VDC
Switching Current Max	: 0.5 A
Termination	: 300 mm extn. leads

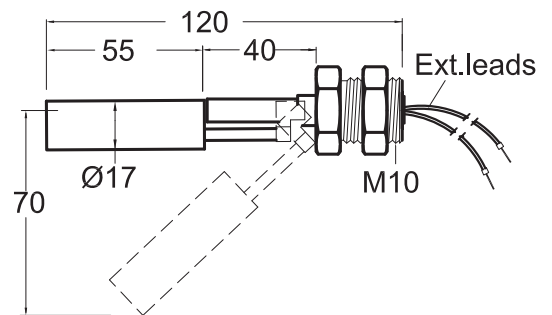

## MFPS - N15E

Liquid Sp. Gr. Min	: 0.8
Temperature Max	: 130 °C
Test Pressure Max	: 5 Kg/cm <sup>2</sup>
MOC	: SS304
Float	: Ø17
Extension	: Without
Connection	: ½"NPT (M)
Switch Capacity	: 10 VA (NO type)
Switch Action	: NO to NC (float rising)
Reversible Switch Action	: Yes
Differential	: ±3 mm
Switching Voltage Max	: 140 VAC/200 VDC
Switching Current Max	: 0.5 A
Termination	: 300 mm extn. leads

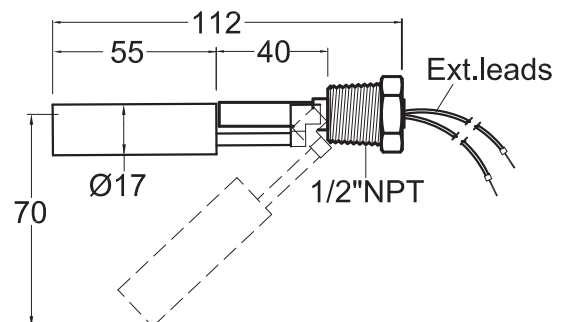

## MFPS - N15C

Liquid Sp. Gr. Min	: 0.8
Temperature Max	: 130 °C
Test Pressure Max	: 5 Kg/cm <sup>2</sup>
MOC	: SS304
Float	: Ø17
Extension	: Without
Connection	: ½"NPT (M)
Switch Capacity	: 10 VA (NO type)
Switch Action	: NO to NC (float rising)
Reversible Switch Action	: No
Differential	: ±3 mm
Switching Voltage Max	: 140 VAC/200 VDC
Switching Current Max	: 0.5 A
Termination	: Plug In Connector

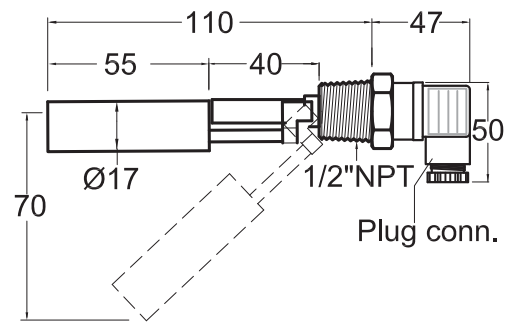
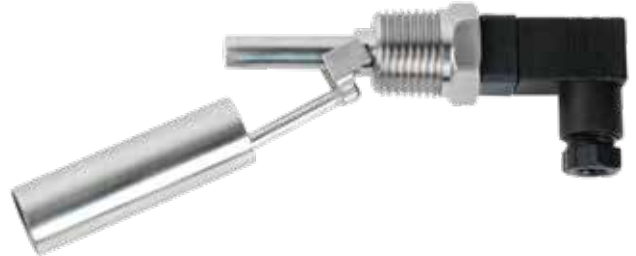

## MFPS - N16C

Liquid Sp. Gr. Min	: 0.8
Temperature Max	: 130 °C
Test Pressure Max	: 5 Kg/cm <sup>2</sup>
MOC	: SS304
Float	: Ø17
Extension	: 110 mm
Connection	: 52 sq. 54 PCD Flange
Switch Capacity	: 10 VA (NO type)
Switch Action	: NO to NC (float rising)
Reversible Switch Action	: No
Differential	: ±3 mm
Switching Voltage Max	: 140 VAC/200 VDC
Switching Current Max	: 0.5 A
Termination	: Plug In Connector

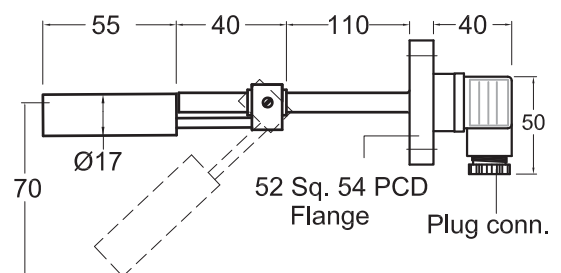

## MFPS-N16J

Liquid Sp. Gr. Min	: 0.8
Temperature Max	: 130 °C
Test Pressure Max	: 5 Kg/cm <sup>2</sup>
MOC	: SS304
Float	: Ø17
Extension	: 110 mm
Connection	: 52 sq. 54 PCD Flange
Switch Capacity	: 10 VA (NO type)
Switch Action	: NO to NC (float rising)
Reversible Switch Action	: No
Differential	: ±3 mm
Switching Voltage Max	: 140 VAC/200 VDC
Switching Current Max	: 0.5 A
Termination	: Cast Al. Enclosure IP66

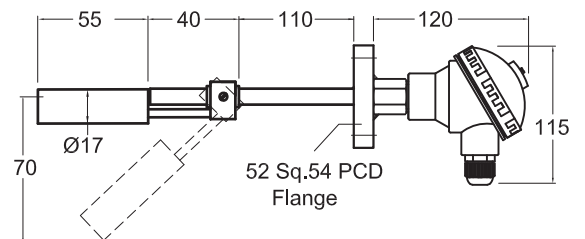

## MFPS - N16F

Liquid Sp. Gr. Min	: 0.8
Temperature Max	: 130 °C
Test Pressure Max	: 5 Kg/cm <sup>2</sup>
MOC	: SS304
Float	: Ø17
Extension	: 110 mm
Connection	: 52 sq. 54 PCD Flange
Switch Capacity	: 10 VA (NO type)
Switch Action	: NO to NC (float rising)
Reversible Switch Action	: No
Differential	: ±3 mm
Switching Voltage Max	: 140 VAC/200 VDC
Switching Current Max	: 0.5 A
Termination	: Cast Al. Enclosure Exd Gr. IIB

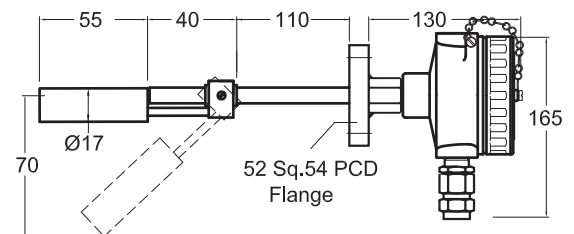

# PUNE TECHTROL PRIVATE LIMITED

CIN: U31909PN1997PTC063403



Regd. & Sales: S-18, MIDC Bhosari, Pune - 411026, India  
+91-20-66342900 | ho@punetechtrol.com

Works: J-52/7, MIDC Bhosari, Pune - 411026, India  
+91-20-67313600 | www.punetechtrol.com